

## DPA-6 Air Hydraulic Pumps

- Internal relief valve protects circuit components, air inlet filter protects motor .
- High pressure output, light weight by aluminum alloy reservoir.
- Serviceable pump motor is not a "throw away", providing economical repair.
- Permanently vented reservoir cap.
- Three-position treadle provides cylinder advance, hold and retract operation.
- Equipped with air coupler, easy for using.
- dBA 85 at 700bar for all DPA-6 pumps, lower noise.

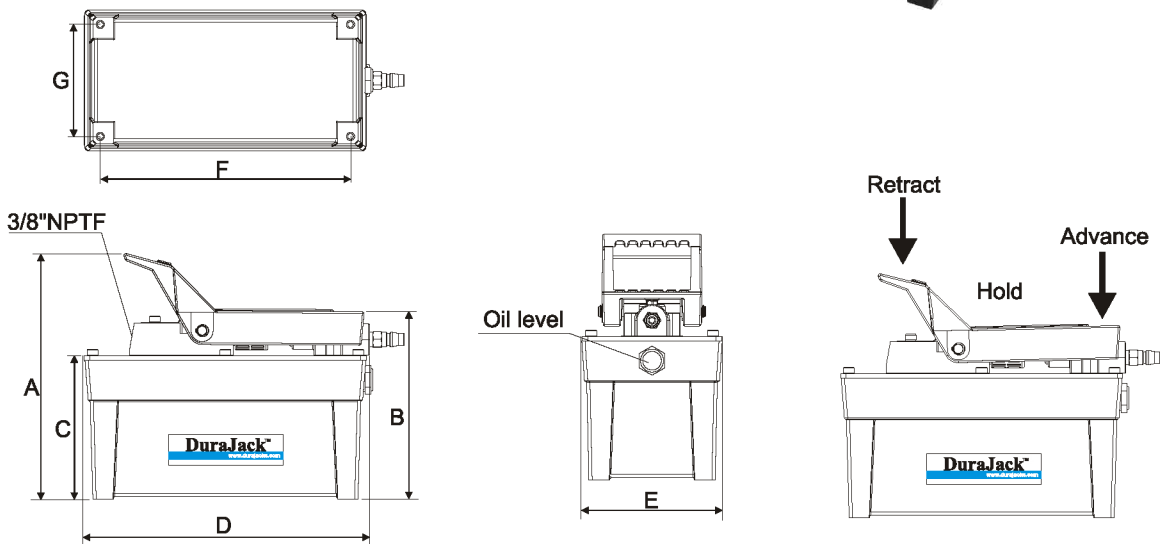

DPA-6



Model Number	Usable Oil Capacity	Pressure Rating		Air Pressure Range	Output Flow Rate (noload)		Dimensions(mm)						W.t (Oil)	
							A	B	C	D	E	F		G
DPA-6	2	700	10,000	6-10	1.24	0.16	225	171	131	260	128	228	102	8.2